

## Assembly Instructions



Model: PP72

### Step 1

Lay Tabletop bottom side up on a smooth flat surface.  
Attach Legs to Tabletop using (8) 3 1/2" bolts and nuts.

### TOOLS NEEDED

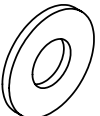
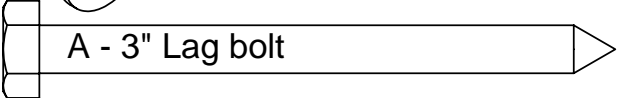
7/16 Socket drive

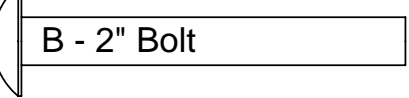
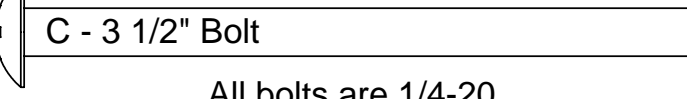
Qty.	Description
6	 1/4" Washer
6	 A - 3" Lag bolt
24	 1/4-20 Flange Nut
8	 B - 2" Bolt
16	 C - 3 1/2" Bolt
All bolts are 1/4-20	

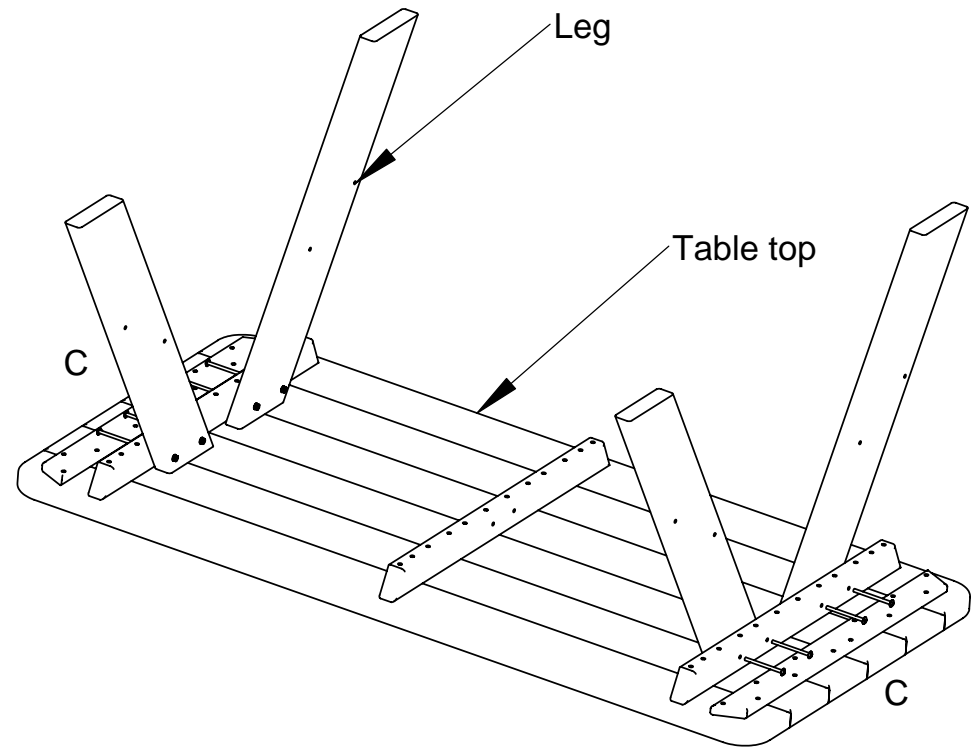

\*See other side\*

Updated: 5/19/06

## Step 2

Attach Seat support to Legs using (8) 3 1/2" bolts and nuts.

Seat support note: Face the hole marked "center" towards the inside

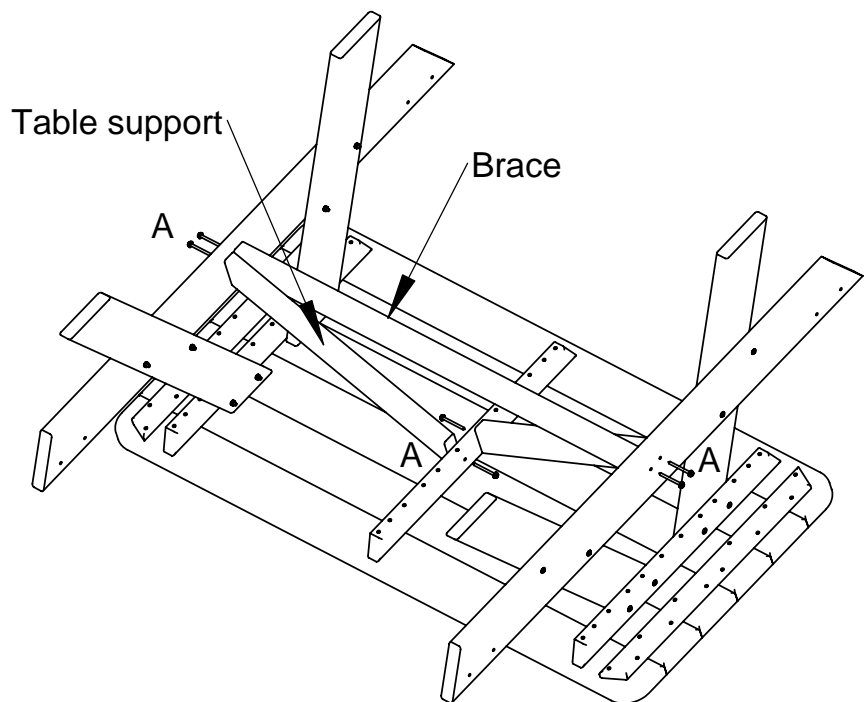
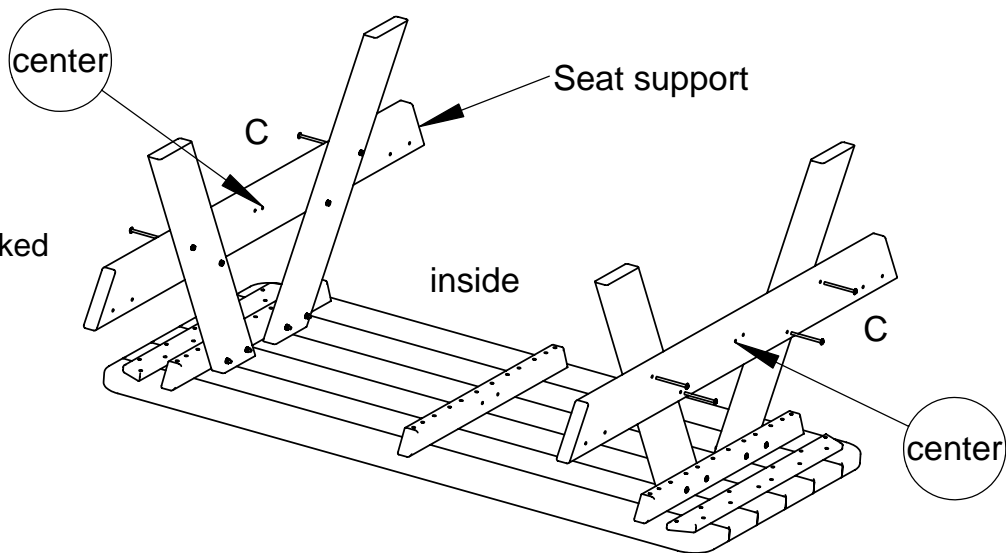

## Step 3

Attach Brace to Seat support with the center hole using (2) 3" Lag bolts and washers

Attach Table supports to the center of the Tabletop  
Attach Table supports to Seat support using (4) 3" Lag bolts and washers

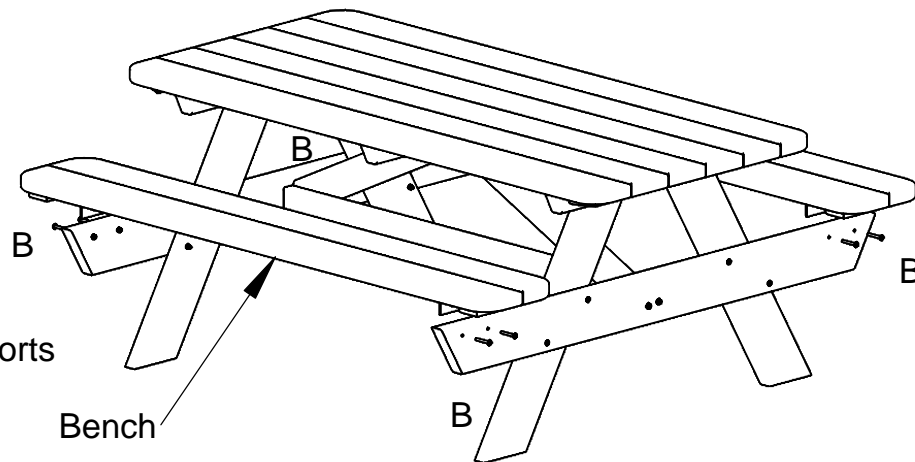

## Step 4

Set table upright  
Attach benches to the seat supports using (8) 2" bolts and nuts

Tighten all nuts firmly